

**CITY OF CLAWSON
OAKLAND COUNTY, MICHIGAN
ORDINANCE NO. 670**

AN ORDINANCE TO AMEND CHAPTER 34 OF THE LAND DEVELOPMENT REGULATIONS OF THE CODE OF ORDINANCES, TO REPEAL DIVISION 23. CMD-1 DISTRICT IN ITS ENTIRETY AND REPLACE IT WITH A NEW DIVISION 23. CITY CENTER DISTRICT AS FOLLOWS:

THE CITY OF CLAWSON HEREBY ORDAINS:

Division 23 of Chapter 34 shall be amended as follows:

PART I: Sec. 34-1191. Scope of division; statement of intent.

- (a) The provisions of this Division apply to the City Center District.
- (b) *Statement of Intent.* The intent of the City Center District and any other districts created and determined to be complimentary with the implementation of the *Downtown Clawson Urban Framework Design Plan* (Framework Design Plan) adopted by the City of Clawson is to preserve and enhance the “main street” character of Clawson with limited height structures, enhanced pedestrian traffic, reduced roadway access, mixed commercial and residential developments, limited signage dedicated to advertising local business’, all of which ~~is~~ are compatible and necessary to accomplish the “main street” features and characteristics set forth in the Framework Design Plan. To encourage such features, future development of the City Center District is intended to encourage and accomplish the following planning considerations all of which are determined to be compatible with the intended development of the district. The City Center District is being adopted to implement the intent of the Master Plan, strengthen, clarify and revise current Ordinances in order to support the traditional town development style as set forth in the Framework Design Plan. Further, the intent of the district is to foster resident and pedestrian access to commercial properties, designed to compete with business concentrations outside the City of Clawson that has resulted in the loss of substantial business development within the Downtown area, and to create an appearance within the City Center District that has uniformity in appearance and those characteristics that encourage pedestrian traffic to the mixed retail centers within this City Center District. The district is also intended to accomplish the following:
- (1) Serve as a downtown neighborhood and community shopping area which is functionally and architecturally integrated with other uses in the area;
 - (2) Encourage a mixed use environment;
 - (3) Encourage pedestrian oriented buildings and uses;
 - (4) Encourage vehicular access to parking lots from alleys rather than streets;
 - (5) Encourage multiple story buildings;
 - (6) Encourage shared parking and access;
 - (7) Encourage buildings to be located at the edge of the public right-of-way;
 - (8) Recognize and affirm the function of the traditional urban downtown center;
and
 - (9) To the extent not inconsistent with Division Three (3) of Article X, Zoning, of the Land Development Code (LDC), all nonconforming uses or structures within the City Center District shall adhere to the extent practicable to the requirements of the City Center District Ordinance and the applicable site plan review and special approval land use criteria.

Sec. 34-1192. Permitted principal uses, uses permitted after administrative approval and uses permitted after special approval.

- (a) In City Center District, no uses shall be permitted except the following:
- (1) Uses similar to those identified in this section, the City's Master Plan and the Framework Design Plan.
 - (2) Uses and structures accessory to those listed in this section, subject to the provisions in Sec. 34-1032.
 - (3)
 - (a) Retail businesses which supply commodities (for consumption) on the premises for persons residing in the area, such as: groceries, meats, dairy products, alcoholic beverages, baked goods or other foods, ice cream, drugs, dry goods, and tobacco products. NO such use shall be located above the second floor of a building, be auto service/supply related, or be serviced by a drive-through facility.
 - (b) Retail establishments which offer comparison goods (for personal use) for residents, such as: bicycle sales, jewelry stores, hobby shops, music stores, clothing and shoe stores, sporting goods stores, office supply stores, notions, hardware, books, stationary and school supplies, flowers, periodicals, small household articles, and other specialty retail stores similar to the above, as determined by the Planning Commission. No such use shall be located above the second floor of a building or be serviced by a drive-through facility.
 - (c) Antique retail sales establishments located on the ground or second floor of a building.
 - (4) Retail establishments which offer comparison goods (for the home) for sale: such as furniture stores, carpet stores, hardware stores, household appliance stores, paint and wallpaper stores and other specialty retail stores catering to home improvement, customary and usual residential needs. No such use shall be located above the second floor of a building or be serviced by a drive-through facility.
 - (5) Artisan uses such as sculpting, metal works, painting, and other similar studios, subject to the following conditions:
 - a. When including a retail sales component, the use shall be located on the ground floor of a building.
 - b. Without a retail sales component on-site the use shall not be located on the ground floor of a building.
 - (6) Restaurants and taverns where the patrons are served while seated, and subject to the following conditions:
 - a. No such use shall be located above the second floor of a building, with the exception of rooftop restaurants which are part of and work in conjunction with a first or second story restaurant/tavern.
 - b. No drive-through facilities are permitted.
 - c. Limitation of Section 531, Quota Licenses (MCLA 436.531, as amended). Under the current requirements of Section 531 (MCLA 436.531, as amended), the City has issued fourteen (14) quota liquor licenses. No additional licenses shall be issued under this Section. Notwithstanding the limitations of Section 531, the City may issue additional licenses authorized by State law and action of the City Council, subject to the following considerations:
 - Type of activities being proposed.

- Proximity to residentially zoned and/or used properties (i.e. distinct, unique and innovative).
 - Proximity to schools, churches, foster care, day care and other similar facilities as defined by the State of Michigan.
 - Proximity to identical uses or licensed establishments.
 - Existence or potential off-site impacts (light, sound, litter, etc.)
 - Proximity to off-street parking lots.
 - Extent of investment required.
 - Extent to which additional license complements the downtown area.
 - Public benefit to be served or arising from the issuance of an additional license.
 - Extent to which additional services will be required, demanded or necessary.
 - Extent to which the proposed development fulfills the guidelines of the Downtown development Authority (DDA).
- (7) Beauty shops, barbershops and similar establishments. All such uses shall not be located above the second floor of a building.
- (8) Establishments which perform services such as: watch, radio, television, clothing and shoe repair, locksmiths, and similar establishments. All such uses shall not be located above the second floor of a building or be serviced by a drive-through facility.
- (9) Establishments which perform services such as photo processing outlets and photocopying establishments. All such uses shall not be located above the second floor of a building or be serviced by a drive-through facility.
- (10) Office uses, including offices for administrative services, accounting, financial and investment, clerical, education, executive, insurance, professional, real estate, research, sales agent, stock broker, and other similar office uses, subject to the following conditions:
- a. All such uses shall be located above the ground floor of a building.
 - b. Office uses may be located on the same floor as a residential use, and in some cases may share the same space (live/work unit).
- (11) Multiple family dwellings, subject to the following conditions:
- a. No dwelling shall be located on the ground level of the building.
 - b. Dwelling units shall meet minimum floor area requirements for R-2 district, per Sec. 34-661.
- (12) Home Business located above the ground floor of a building, but if retail or service-oriented, the use may be located on the ground floor. Any massage activities, except those exempt under Sec. 18-153 of Article 4 of Chapter 18 of the Code of Ordinances, is prohibited from being considered as a home business.
- (13) Public parks and plazas when combined with a commercial use or as the sole use on a site.
- (14) Rooftop restaurants involving the construction of permanently anchored structures, with or without the sale of alcoholic liquor, subject to the following conditions:
- a. The hours of the rooftop seating area shall not create a nuisance to the adjoining uses.
 - b. For any establishment desiring to serve alcoholic liquor there must be advanced approval for outdoor sales from the Michigan Liquor Control Commission and the City of Clawson.

- c. There must be sufficient insurance to cover or indemnify the City of Clawson.
 - d. The applicant in receiving approval for a rooftop café or eating area must acknowledge that such use can be immediately revoked for the violation of any of the conditions of that use; a violation of any applicable provision of Sec. 34-1192; a violation of any provision of a plan of operation under Sec. 6-65; development incentives under Sec. 34-1194; or an unauthorized modification of use from that originally described in the application and approval of the Planning Commission.
 - e. All such operations shall not commence prior to April 15 of any given year and shall cease by November 15 of that same year.
 - f. No signage shall be permitted within the outdoor café or eating area, including umbrella signs, banners, etc. The only permitted signage shall be in association with the interior use and shall be consistent with the requirements of Sec.34-1195(f).
- (b) The following uses may be permitted in the City Center district, subject to the conditions specified for each use, review and recommendation of the City Planner, and final approval by the Director of Building and Planning:
- (1) Outdoor cafes or eating areas where patrons are served while seated in the public sidewalk and/or on private property, subject to the following requirements:
 - a. To allow for pedestrian circulation, a minimum of six (6) feet of sidewalk from the backside of the curb and leading to the entrance of the establishment shall be maintained free of tables and other encumbrances. Less than six (6) feet may be considered when the existing sidewalk is less than ten (10) feet wide and providing adequate maneuvering space remains. However, under no circumstance shall the café or eating area substantially cause nor interfere with the customary and routine pedestrian traffic on the adjoining public way nor contribute to any disruption to surrounding businesses. Any required modification of the abutting public way necessitated by the existence of an outdoor café shall be at the expense of the applicant.
 - b. Planters, posts with ropes or other decorative removable enclosures are permitted as a way of defining the area occupied by the café.
 - c. Where appropriate, outdoor cafes shall be required to provide additional trash receptacles in the outdoor eating area.
 - d. Tables, chairs, planters, trash receptacles and other elements of street furniture shall be compatible with the architectural character of the building in terms of style, color, materials and similar elements.
 - e. All furniture in the public sidewalk shall be portable and removed or secured when not in use.
 - f. The hours of the outdoor seating area shall not create a nuisance to the adjoining uses.
 - g. For any establishment desiring to serve alcoholic liquor there must be advanced approval for outdoor sales from the Michigan Liquor Control Commission and the City of Clawson.
 - h. There must be sufficient insurance to cover or indemnify the City of Clawson.

- i. The applicant in receiving approval for an outdoor café or eating area must acknowledge that such use can be immediately revoked for the violation of any of the conditions of that use; a violation of any applicable provision of Sec. 34-1192; a violation of any provision of a plan of operation under Sec. 6-65; development incentives under Sec. 34-1194; or an unauthorized modification of use from that originally described in the application, review and approval of the Director of Building and Planning.
- j. All such operations located within a public right-of-way, shall not commence prior to April 15 of any given year and shall cease by November 15 of that same year. The duration may be modified by the Director of Planning and Building, upon special request by an applicant, substantiated with adequate reasons.
- k. No signage shall be permitted within the outdoor café or eating area, including umbrella signs, banners, etc. The only permitted signage shall be in association with the interior use and shall be consistent with the requirements of Sec.34-1195(f).

(2) Outdoor retail display areas, subject to the following conditions:

- a. To allow for pedestrian circulation, a minimum of six (6) feet of sidewalk from the backside of the curb and leading to the entrance of the establishment shall be maintained free of encumbrances. Less than six (6) feet may be considered when the existing sidewalk is less than ten (10) feet wide and providing adequate maneuvering space remains.
- b. Planters, posts with ropes or other decorative removable enclosures are permitted as a way of defining the area occupied by the display area.
- c. There must be sufficient insurance to cover or indemnify the City of Clawson.
- d. No signage shall be permitted within the outdoor retail display area. The only permitted signage shall be in association with the interior use and shall be consistent with the requirements of Sec.34-1195(f).

(3) Rooftop seating areas comprised of fully removable furniture and decor, with or without the sale of alcoholic liquor, subject to the following conditions:

- a. Temporary coverings are permitted provided they are removed at the end of each season.
- b. The hours of the rooftop seating area shall not create a nuisance to the adjoining uses.
- a. For any establishment desiring to serve alcoholic liquor there must be advanced approval for outdoor sales from the Michigan Liquor Control Commission and the City of Clawson.
- b. There must be sufficient insurance to cover or indemnify the City of Clawson.
- c. The applicant in receiving approval for a rooftop café or eating area must acknowledge that such use can be immediately revoked for the violation of any of the conditions of that use; a violation of any applicable provision of Sec. 34-1192; a violation of any provision of a plan of operation under Sec. 6-65; development incentives under Sec. 34-1194; or an unauthorized modification of use from that originally described in the application and approval of the Director of Building and Planning.

- d. All such operations shall not commence prior to April 15 of any given year and shall cease by November 15 of that same year.
 - e. No signage shall be permitted within the outdoor café or eating area, including umbrella signs, banners, etc. The only permitted signage shall be in association with the interior use and shall be consistent with the requirements of Sec.34-1195(f).
- (c) The following additional uses may be permitted in the City Center district, subject to the conditions specified for each use, review and approval of the Planning Commission, and the requirements set forth in Sec. 34-520. Uses permitted after Special Approval:
- (1) Financial institutions, including banks, credit unions, and savings and loan associations, subject to the following conditions:
 - a. All such uses shall not be located above the second floor of a building.
 - b. No drive-through facilities are permitted when fronting on Main Street or 14 Mile Road.
 - (2) Theaters, where completely enclosed.
 - (3) Commercial parking garages, subject to the following:
 - a. The garage may be self contained or combined with a building which fronts on a perimeter public street.
 - b. The garage shall not be visible from Main Street or 14 Mile Road.
 - c. Access to the garage shall be from a rear or side alley.
 - d. Garages shall be no less than two (2) stories.
 - (4) Health and physical fitness centers, including but not limited to, exercise gyms and workout centers, subject to the following conditions:
 - a. A stand alone use may be located on the ground floor of a building when operating for a minimum of five days per week and not less than 8 hours per day.
 - b. A facility associated with a mixed use development may be located above the ground floor of a building when operating for a minimum of five days per week and not less than 8 hours per day.
 - c. Dance and gymnastic studios, yoga, martial arts and other similar uses shall only be located above the ground floor of a building when operating less than five days a week and less than five hours per day.
 - (5) Commercial recreation, including, but not limited to, pool halls, arcades, parlors and skating rinks, subject to the following conditions:
 - a. When fronting on Main Street or 14 Mile Road, all such uses shall be located above the ground floor of a building.
 - b. When fronting on any other City street, the use may be located on the ground floor of a building.
 - c. When in conjunction with a restaurant, bar or any retail use, the use may be located on the ground floor of a building, provided the use is secondary to one of the principle uses noted above.

- (d) Permitted and special land uses within existing single story structures. In order to encourage occupancy of existing vacant storefronts within the downtown and to enable establishment of successful business in accordance with the City's Master Plan and Downtown Design Framework Plan, the following guidelines shall apply:
 - a. See Sec. 34-1194 for development incentives. Also refer to Section 34-1195 for required improvements to existing multiple story structures.
 - b. All new construction built on vacant property shall have multiple stories. The requirement shall also apply to redevelopment sites, where the existing building(s) are completely demolished. A building/structure shall be considered to be completely demolished if more than 50 percent of its market value is destroyed for any reason, natural and/or man-made.
- (e) All existing buildings with two or more stories shall be required to bring the upper stories into compliance with the Ordinance standards at such time when the first story is vacated and ready for occupancy by a new tenant.

Sec. 34-1193. Site Plan Review Process

Planning Commission Review. Notwithstanding the provisions of this section, all uses in the City Center District are subject to the review process of Division 4, of Article X, Zoning, of the LDC and shall require approval from the Planning Commission, unless otherwise provided for in Section 34-611. Any change to an approved site plan shall also comply with Section 34.602.

Sec. 34-1194. Development Incentives.

A contract agreement may be available to any applicant under the circumstances in which the applicant can meet the following qualifications and desires to take advantage of the benefits offered under the provisions of this Sec. 34-1194.

- (a) By entering into a contract agreement the applicant MAY be entitled through negotiation to receive all or a portion of the following:
 - (1) Financial assistance or staffing from the City on any applicable grants that may qualify for such a development or project;
 - (2) To the extent applicable, the waiver of real or personal property taxes for a negotiated period of time;
 - (3) A waiver of permit, inspection or certain infrastructure fees or finance requirements;
 - (4) A modification of any consulting fees the City might customarily charge for such a development;
 - (5) A modification of any fee-in-lieu or payment period authorized, allowed or established under Division 20 of Article 34;
 - (6) Joint marketing and promotion grants for a consortium of businesses which is intended to ensure their joint survival while taking advantage of the economies of scale;
 - (7) Infrastructure funding assistance for new or "start-up" businesses. The funds may go towards improvements such as plumbing, electrical, signage, brick pointing, painting, lighting or any indoor or outdoor repairs deemed appropriate;
 - (8) Matching grants for "start-up" businesses needing assistance during their first year of operation;
 - (9) Assistance with internal training based upon a demonstration that the training will contribute to the economics and labor market of the City;

- (10) Assistance in providing access to advanced technology such as high speed internet, wireless internet, and website development;
 - (11) Beautification grants intended to enhance the outside entrance of local businesses; and/or
 - (12) Matching grant funds for organizations designated by the IRS under as 501(c).
- (b) For this opportunity to arise, some or all of the following standards must be met:
- (1) A non-conforming structure is being eliminated; a nonconforming use is being terminated; or a conforming structure is being substantially changed;
 - (2) Encourages the use of land in accordance with its character and adaptability and is consistent with the Statement of Intent in Sec. 34-1191(b);
 - (3) Encourages innovation in land use planning; use of LEED (Leadership in Energy and Environmental Design) or environmentally friendly building design with the use of sustainable materials and energy;
 - (4) There exist a plan for adequate parking for employees and patrons separate from public parking adjacent to the use and/or on roadways abutting the site;
 - (5) As the result of the development proposed, there is a recognizable and material benefit that will occur to the user of the services or facilities offered as well as to the community which other wise would not exist;
 - (6) In all other respects the contract agreement will improve, enhance, or materially serve the public health, safety and welfare of the community without a substantial burden being added or placed on the public services, road improvements or utilities;
 - (7) The applicant is willing to assume certain expenses for the construction and/or installation of public utilities or infrastructure incurred by the City which will arise from the approval of such a development. In addition, the applicant is willing to assume a portion of the City's professional fees and expenses directly attributable to a project constructed under this provision.
 - (8) To the extent possible, there exists an enhancement in the uses outlined in the City Center District ordinance;
 - (9) To the extent available, there is a recognition and use of open space for public amenities such as artwork display, open space for congregating, a plaza, or a space devoted for civic events sponsored by the City; and
 - (10) The proposed development is consistent with the goals and policies of the City's Master Plan and the Framework Design Plan.
- (c) A contract agreement may be applied for in the City Center District only. The granting of a contract agreement application shall require special approval subject to Sec. 34-520.
- (d) Any land use authorized in this Division may be included in a contract agreement, subject to adequate public health, safety, and welfare protection mechanisms being designed into the development to ensure the compatibility of varied land uses both within and outside the development.
- (e) In addition to the qualifications of this section, the applicant for a contract agreement must demonstrate that all of the following will occur as a result of the contract agreement treatment:
- (1) Granting of the contract agreement will result in at least one (1) of the following:

- a. A recognizable and material benefit to the ultimate users of the project and to the community, where such benefit would otherwise be unfeasible or unlikely to be achieved without application of the contract agreement regulations; or
 - b. A non-conforming use shall, to a material extent, be rendered more conforming, or less offensive, to the zoning district in which it is situated.
 - c. An innovative design that is more compatible with the guidelines of the City's Master Plan and the Framework Design Plan.
 - d. Implications of the goals described in Sec. 34-1191(b).
- (2) The proposed type and density of use shall not result in an unreasonable increase in the need for or burden on public services, facilities, roads and utilities.
 - (3) The proposed development shall be consistent with the public health, safety and welfare of the City.
 - (4) The proposed development shall not result in a negative economic impact upon surrounding properties.
 - (5) The proposed development shall be under single ownership and/or control such that there is a single person having responsibility for completing the project in conformity with this Article.
- (f) Upon determining that a development qualifies for a contract agreement for a particular area of the, City Center District before construction is commenced there shall be a written agreement between the developer, the applicant and the City of Clawson embodying the terms and provisions of the contract agreement. Any such agreement will also have a dispute resolution clause, the purpose of which is to forego the necessity of any litigation in the event a dispute arises pertaining to the terms and provisions of the agreement implementing the contract agreement.

Sec. 34-1195. Development Standards.

In order to ensure compatibility with the design standards for the City Center District and provide information to encourage compatibility with the applicable components of the City's Master Plan and Framework Design Plan, applicants shall refer to the City Center District/DDA design guideline checklist, which shall be provided to all applicants as part of the application form.

- (a) *Area, height, bulk and placement requirements.* Buildings and uses in the City Center District are subject to the following:
 - (1) Front yards. All buildings shall be located at the build-to-lines at edge of the road right-of-way. The build-to-lines are intended to provide a street wall which is pedestrian oriented (see Figure 1).

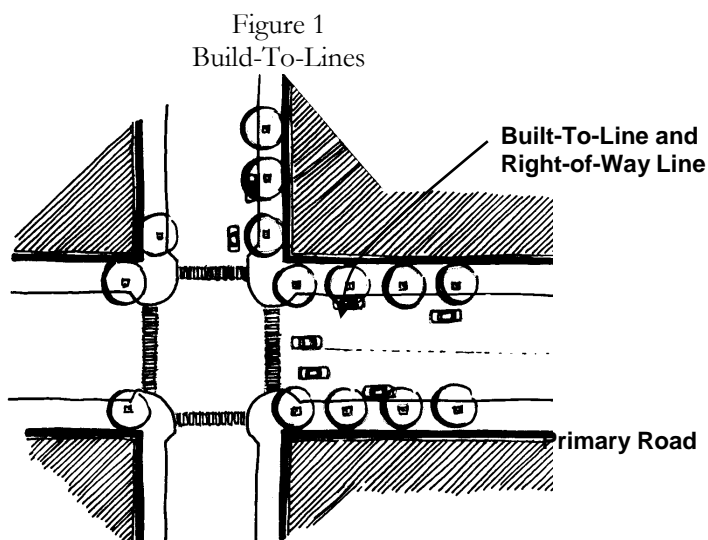

Build-to-lines may include a necessary degree of flexibility by permitting the following deviations:

- a. Belt courses, sills, lintels, and cornices may project up to eighteen (18) inches into the public right-of-way.
 - b. Balconies with a clearance of no less than fifteen (15) feet above grade may encroach up to four (4) feet into the public right-of-way.
 - c. Canopies and awnings associated with a ground floor use may encroach up to ten (10) feet provided there is no less than a ten (10) foot clearance above the public sidewalk and that ground supports are not required.
 - d. Projecting signs with a clearance of no less than eight (8) feet may encroach up to three (3) feet when attached to the face of the building. Up to an additional three (3) foot encroachment is permitted when attached to the underside of a projecting canopy or awning (suspended sign).
 - e. Display, show or bay windows may project up to eighteen (18) inches provided there is a minimum of eighteen (18) inches of clearance between said projections and the sidewalk.
 - f. Decorative roofs and entry features with a clearance of no less than ten (10) feet may project up to three (3) feet.
 - g. Non-residential doorways may be recessed up to eight (8) feet. Residential doorways located within a courtyard may be recessed up to twenty (20) feet.
- (2) Rear and side yards. There is no rear or side yard setback requirement provided all buildings are served by a rear alley or other demonstrated means of rear access.
- (3) Height. No building or structure shall exceed four (4) stories or fifty (50) feet. However, all structures above two (2) stories when located at the build-to-line, shall be stepped back to ensure adequate natural light levels are maintained at the street. For every two (2) feet above thirty (30) feet or two (2) stories, the building shall be setback one (1) foot. Figure 2 depicts the setback requirements.

Figure 2
Stepped-Back Height Requirements



- (4) Floor area. No commercial/retail, service or restaurant use shall have a ground floor area of greater than 5,000 square feet unless located in a building with two (2) or more stories or unless it is an existing nonconforming structure.

- (b) *Access.* Access to public roads for both pedestrians and vehicles shall be controlled in the interest of public safety. Each building shall be subject to the following:
- (1) Rear loading access. All buildings shall be served by a rear alley or other demonstrated means of rear access for the loading and unloading of deliveries (see Figure 3).

Figure 3
Access

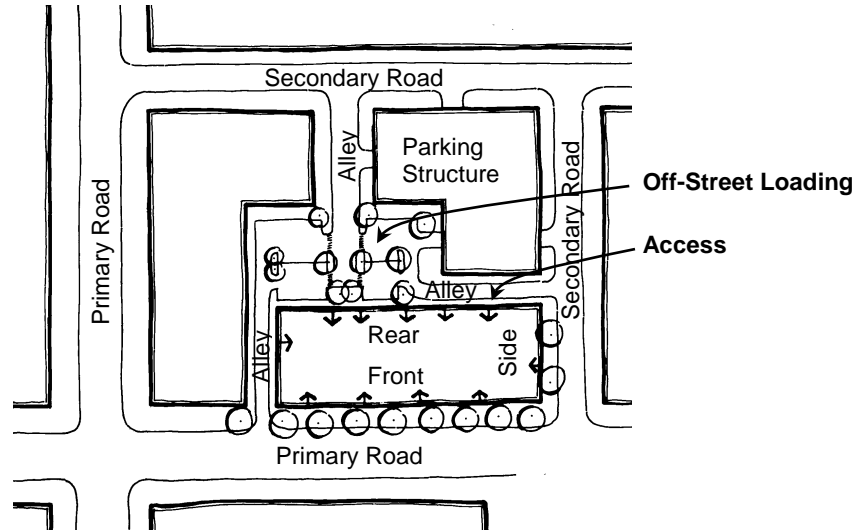

- (2) Pedestrian access. Where feasible a pedestrian walkway perpendicular to the public road and between the buildings shall be provided and shall count towards the open space and community design feature requirements of Sec. 34-1195(g). A rear public entrance shall also be provided for each building fronting on a public road.
 - (3) Driveways. Where feasible, driveways shall be consolidated to minimize congestion and potential conflicts on the adjacent public roads.
- (c) *Facades, glazing.* It is the intent of the district to provide an environment of high quality and complementary building architecture and site design. Special emphasis shall be placed upon methods that encourage tasteful, imaginative design for individual buildings, and to create a complex of buildings compatible with the streetscape.
- (1) Miscellaneous design criteria.
 - a. Building entries shall be readily identifiable and accessible, with at least one (1) main entrance facing and open directly onto the public sidewalk. A secondary public entrance shall be provided within the rear of the building.
 - b. Architecture will be evaluated based upon its compatibility and relationship to the adjacent buildings and uses, and the City Center District as a whole.
 - c. Architectural plans shall confirm that materials are appropriate for the location on the building. In the event that it is determined by the Building Official that the building materials are inappropriate they shall be replaced at the owner's expense.
 - (2) Building massing and form.
 - a. Architectural interest shall be provided through the use of repetitious patterns of color, texture and material modules, at least one (1) of which shall repeat horizontally. Each module should repeat at intervals of no more than fifty (50) feet.

- b. Building facades shall incorporate recesses, projections, or spandrel windows along at least twenty (20) percent of the length of the facade. The Planning Commission has the discretion to modify this requirement based upon input from the City Planner/Director of Planning and Building Department, and the proposed design meeting the intent of the City Center District.
- c. At least sixty (60) percent of the ground floor of a building facing a public street, courtyard or public square shall consist of glazed windows or glazed doors. Glazing can be clear or tinted with grey or brown color; however percentage tinting shall not exceed 20% at street level. At least forty (40) percent of the upper floor of a building facing a public street, courtyard or public square shall consist of clear windows. The Planning Commission has the discretion to modify this requirement based upon input from the City Planner/Director of Building and Planning Department, and the proposed design meeting the intent of the City Center District.
- d. Primary building entrances shall be clearly defined and recessed or framed by a sheltering element such as an awning, arcade or portico in order to provide shelter from the summer sun and winter weather.
- e. The buildings facing a public road, and contained within a given block, shall if and when practicable, appear to have a continuous façade. The only breaks shall be associated with the pedestrian and vehicular access points.

(3) Materials.

- a. Low maintenance shall be a major consideration.
- b. Materials shall blend with those existing on adjacent properties, to the extent feasible.
- c. One dominant material shall be selected, with a preference towards masonry and stone. Products such as dryvit and EFIS are prohibited on the ground floor of all buildings. Exterior construction materials shall be consistent with the City's design standards.
- d. The construction treatment shall not vary between the front and rear facades.

(4) Building roofs.

- a. In instances where roof vents, roof-mounted mechanical equipment, pipes, etc., can be viewed from above or below, they shall be grouped together, painted to match roof color to reduce their appearance, and screened from view.
- b. A parapet of at least forty-two (42) inches high shall screen the mechanical equipment on a flat roof.
- c. Mansard roofs are discouraged.

(5) Color and texture.

- a. Simple and uniform texture patterns are encouraged.
- b. Variations in color shall be kept to a minimum.
- c. Colors shall be subdued in tone, of a low reflectance and of neutral or earth tone colors.
- d. Accent colors used to express corporate identity or a business theme are discouraged.

- e. The color of all awnings or canopies shall complement the building colors.
 - f. Neon tubing for any use, excluding signage, is prohibited.
 - g. The use of the adopted DDA color palette is strongly recommended.
- (d) *Off-street parking.* Buildings and uses in the City Center District shall be subject to the parking requirements of Division 20 except as provided below:
- (1) Under those circumstances in which a developer or owner of a building has provided alternative arrangements or made commitments for patron or customer parking, or has entered an Agreement under Sec. 34-1194, the parking requirements for first floor use in a multiple story building shall be exempt or modified from the requirements of Division 20, Off-Street Parking and Loading of Article 34 of the Land Development Code.
 - (2) In addition to the modification provisions to parking within Divisions 20, Sec. 34-1072(6), the Planning Commission may modify parking requirements for single story structures where all of the following requirements are met:
 - a. Construction materials and design are exemplary and implement the goals, objectives and policies of the City's Master Plan and the Framework Design Plan.
 - b. An existing mansard roof is being removed and not being replaced.
 - c. The applicant demonstrates the availability of shared parking within 300 feet of the subject site, as measured from property line to property line. Proof of availability of parking shall be demonstrated through submission of a signed parking agreement with the other property owner(s).
 - d. No accent colors are being used to express corporate identity or a business theme.
 - e. Use of the adopted DDA color palette is encouraged.
 - f. Building signage is limited to architecturally compatible wall, projecting and/or suspending signage.
 - g. Less than the permitted quantity (area and number) of wall signage is being proposed.
 - (3) All upper floor office and residential uses shall be required to provide off-street parking spaces in accordance with Division 20 of this Article, and the following:
 - a. Users are encouraged to provide collective parking facilities in accordance with Sec. 34-1072(5).
 - b. All parking facilities shall comply with the standards for a commercial parking garage noted in Sec. 34-1195.
 - (4) When an upper floor user is unable to provide all or some of the required off-street parking spaces within reasonable proximity (will be determined by Planning Commission with recommendation from City Planner and Director of Building and Planning to such building or use, the user may request to pay a fee in lieu of parking in accordance with Sec. 34-1073. The cost per parking space, and the payment methods, shall be established from time to time by resolution of the City Council.

- (e) *Off-street loading.* In order to accommodate loading and unloading, all buildings shall be served by a rear alley, or other demonstrated means of rear access, which shall be adequate to accommodate a fire lane along with an area for off-street loading (see Sec. 34-1078). All deliveries shall be received within the rear of the building.
- (f) *Signage.* All signs permitted within the City Center District shall be subject to the requirements of Division 21 of this Article, unless a stricter provision is provided below. The intent of these requirements is to ensure that signs within the City Center District are limited and uniform in size, design, appearance, illumination and materials subject to the criteria set forth below. It is also the intention where applicable, unless expressly stated herein, to follow the illumination requirements of Sec. 34-1035 and 34-1109(f) of the Land Development Code:
- (1) Roof signs are strictly prohibited.
 - (2) Banners promoting community events must comply with the standards adopted by the City Council on July 20, 2004, or as amended.
 - (3) Signs shall be consistent unless otherwise expressed in this Ordinance with the illumination requirements in Sec. 34-1035 and Sec. 34-1109(f) of the Land Development Code.
 - (4) All signs shall be designed so as to be integral and compatible with the architecture of the development of the building in terms of scale, color, materials, graphic design, typography, and lighting.
 - (5) Conceptual sign designs shall be submitted with the site plan and the Planning Commission shall review these conceptual plans together with the site plan.
 - (6) Wall signs for ground floor commercial/retail, service and restaurant uses (see Figure 4):

Figure 4
Wall Signs for Ground Floor Uses



- a. The wall signs for all buildings fronting on Main Street or 14 Mile Road may be integrated into the awning (see Clawson Awning Guidelines). All others shall be flush mounted on the front face of the building.
- b. The wall/awning sign area shall measure no larger than twenty-four (24) square feet per public road frontage. A secondary sign of no greater than twelve (12) square feet shall be permitted at the rear or side entrance.
- c. All walls signs, if illuminated, shall be illuminated in a manner that is not intermittent, nor causing a hazard to others. No awnings shall be internally illuminated.
- d. Temporary window signs are not permitted except as a sign announcing a sale, grand opening, etc. provided they do not cover more than twenty-five percent (25%) of the total window area and no more than fifty percent (50%) coverage per window. A temporary use permit not exceeding four (4) weeks per calendar year will be required from the City. A longer period of time may be permitted by action of ZBA under Sec. 34-1049 of the LDC.

e. Permanent window signs which complement the design criteria set forth in this Section may be permitted under the following circumstances:

- The total sign area does not exceed more than 25% coverage per window.
- The sign lettering shall be placed along the bottom of the window, not to exceed a lettering height of 12 inches.
- When combined with the wall, projecting/suspending sign area, the total area does not exceed seventy-two (72) square feet.
- The sign does not obstruct visibility into the building.
- There shall be no moving or flashing parts.

(7) Suspended or projecting signs for ground floor commercial/retail, service or restaurant uses (see Figure 5):

Figure 5
Suspended or Projecting Signs for Ground Floor Uses

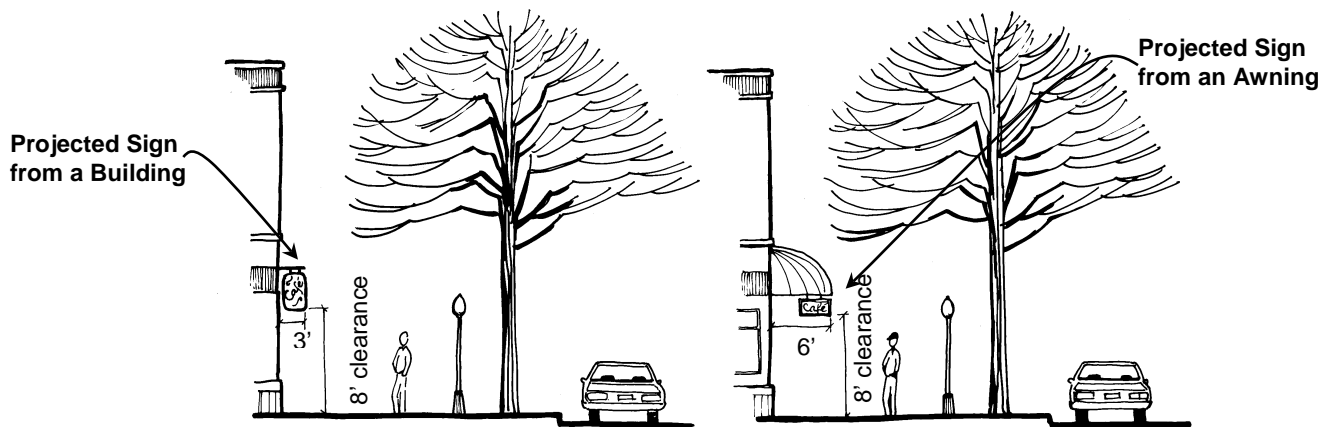

- In addition to the wall signs noted above, buildings fronting on Main Street or 14 Mile Road may have a suspended or projecting sign.
- A suspended or projected sign shall be included within the maximum of twenty-four (24) square feet provided no less than an eight (8) foot clearance is maintained between the suspended sign and the public sidewalk.
- Buildings not fronting on Main Street or 14 Mile Road may request a suspended or projecting sign instead of the flush mounted sign noted above.

(8) Wall signs for upper floor office and residential uses (see Figure 6):

Figure 6
Wall Signs for Upper Floor Uses



- a. When the access to the upper floor uses is exclusively from the front of the building, one (1) wall sign shall be placed on the entrance door and shall measure no larger than two (2) square feet.
 - b. When the access to the upper floor uses is exclusively from the rear of the building, one (1) wall sign shall be placed on the entrance door and shall measure no larger than two (2) square feet. For office uses only, a secondary wall or projecting sign of no greater than six (6) square feet in area may be placed on the front of the building adjacent to the nearest driveway.
 - c. The secondary office wall signs, if illuminated, shall be illuminated in a manner that is not intermittent, nor causing a hazard to others.
- (9) The City Center district has many existing business establishments with non-conforming pylon/pole signs, which are contrary to the intent and image of the City Center area envisioned by the Master Plan and the Design Framework Plan. While removal and replacement of existing non-conforming buildings with new built-to-line structures is encouraged, for existing buildings set back from the front property line, one of the following signage types shall be permitted in lieu of allowable wall signage. This provision shall not be applicable to new buildings, new construction or buildings located at the property line:
- a. Monument signs. A monument sign may be allowed when the Planning Commission determines that a wall sign would not be easily seen from the public street and there is sufficient area on the site to accommodate a freestanding sign.
 - (i) Need. The applicant shall provide line-of-sight diagrams to indicate that the location of buildings on adjacent parcels and/or the setback of the existing building reduce the visibility of any wall sign.
 - (ii) Location. The sign may be located only along a site's frontage, adjoining a public street. Such sign may not be located in an easement or interfere with power lines or other utility systems.
 - (iii) Maximum Area and Height. The sign shall be no more than 20 square feet in size and shall not exceed 5 feet in height from grade to the top of sign.
 - (iv) Design. The design of a monument sign shall be consistent with the overall scale of the building. The design and placement of the sign shall not obstruct traffic safety sight areas.

Figure 7: Monument Sign

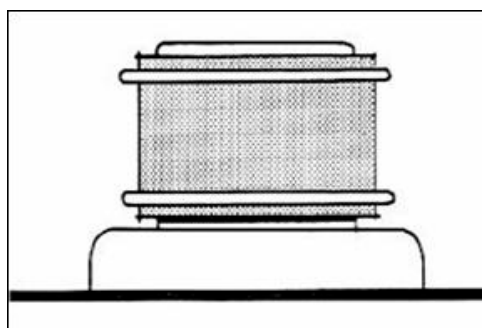

- (v) Landscaping Requirements. Landscaping shall be provided at the base of the supporting structure equal to twice the area of one face of the sign. For example, 20 square feet of sign area = 40 square feet of landscaped area. The Planning Commission may reduce or waive this requirement upon demonstration of potential conflict with existing utilities or other non self-created hardships.

b. Elevated Monument Signs. An elevated monument sign may be allowed when the Planning Commission determines that a wall sign would not be easily seen from the public street and there is sufficient area on the site to accommodate a freestanding sign.

- (i) Need. The applicant shall provide line-of-sight diagrams to indicate that the location of buildings on adjacent parcels and/or the setback of the existing building reduce the visibility of any wall sign.
- (ii) Location. The sign may be located only along a site's frontage, adjoining a public street. Such sign may not be located in an easement or interfere with power lines or other utility systems.
- (iii) Maximum Area and Height. The sign shall be no more than 16 square feet in size and shall not exceed 5 feet in height from grade to the top of sign.
- (iv) Sign Mounting. The sign shall be mounted on one or more posts or have a solid monument-type base. Posts shall not have a diameter greater than twelve (12) inches.

Figure 8: Elevated Monument Sign

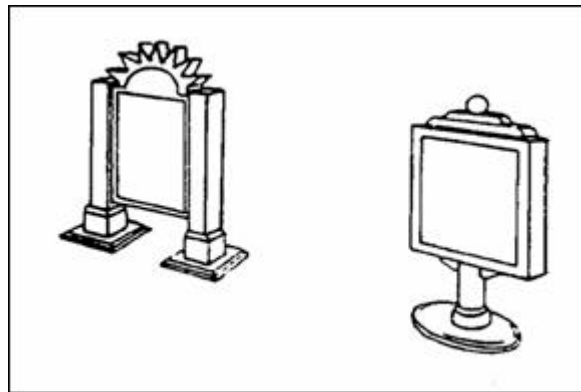

- (10) Blighted Signs. Existing non-conforming signs located within the CMD-1 district shall be permitted to be repaired for maintenance purposes only. Any such sign that is damaged beyond fifty percent of its market value and/or remains in a state of disrepair for a period greater than 90 days after being so designated in writing by the Director of Building and Planning, shall be deemed to be a blight, and will be required to be removed.
- (g) Open space and community design features. The minimum open space and community design requirements are established to provide amenities for downtown residents, promote livability, and help soften the effects of built and paved areas. All new developments shall comply with the following:
 - (1) Commercial/retail, service, or restaurant use. To the extent not in conflict with the provision of Division 23, each storefront shall contribute to the establishment or enhancement of the community by providing at least two of the following: patio/seating area, pedestrian plaza with benches, pedestrian walkways perpendicular to the public road and between the buildings, ornamental planters, bicycle racks, trash receptacles, pieces of art or other such deliberately shaped area and/or a focal feature or amenity that, in the judgment of the City, adequately enhances and/or serves the community and public spaces. Any such areas and/or features shall have direct access to the public sidewalk network and shall be constructed of materials that are comparable to and compatible with the principal materials required of the building and landscape design. Existing amenities installed by the City and/or DDA along the public sidewalk shall not be counted towards the required number of amenities by any individual business along whose frontage such an amenity is located.

- (2) Residential use. Each residential development shall include a combination of courtyards, roof top gardens, balconies, terraces and porches. Where feasible these areas shall be landscaped in accordance with Sec. 34-1034.
- (h) *Lighting.* All lighting shall conform to the requirements of Sec. 34-1035 in order to maintain vehicle and pedestrian safety, site security, and accentuate architectural details. Additional conditions include the following:
 - (1) Architectural building or roof mounted lighting, when used for other than security purposes, may articulate the particular building design, as well as provide the required functional lighting for safety of pedestrian movement.
 - (2) Pedestrian walk lighting shall clearly identify the pedestrian walkway and direction of travel.
 - (3) All proposed lighting must be shielded to direct glare away from public and right-of-way areas.
- (i) *Dumpsters.* All dumpsters shall be contained within the building and/or a fully enclosed structure attached to the building. Trash collection shall be made available from the alley. Where a dedicated alley is not available, alternative means of collection shall be reviewed and approved by the City.
- (j) *Performance Bond.* In cases where the applicant seeks immediate occupancy of the site within an existing building, the Planning Commission may require the submission of a performance bond in an amount equal to the cost of completion of all improvements associated with the approved site plan. This provision does not negate the requirements of the Building Codes.

PART II. Conflicts.

If any provision of the Clawson Land Development Regulations conflicts with this amendment to the regulations, the most restrictive provision shall be applied.

PART III. Severability.

Should any section or part of this ordinance be declared unconstitutional, null or void by a court of competent jurisdiction, such declaration shall not have any effect on the validity of the remaining sections or parts of this ordinance.

PART IV. Adoption.

This ordinance was adopted by the City Council of the City of Clawson by authority of Public Act No. 110 of 2006 further amended as Public Act 12 of 2008, of the Public Acts of Michigan, at a meeting duly called and held on the 6th day of January, 2009, and ordered to be published as prescribed by the law.

STATE OF MICHIGAN)
)
 COUNTY OF OAKLAND)

I, the undersigned, the duly qualified and active City Clerk of the City of Clawson, Oakland County, Michigan, do hereby certify that the foregoing is a true and complete copy of an ordinance made, passed and adopted by the Council of said City at a regular meeting held in the Council Chambers, 425 N. Main Street, MI on Tuesday the 6th day of January, 2009 at 7:30 p.m.; further this Ordinance synopsis was duly published in the January 14, 2009 edition of the Daily Tribune, a newspaper of general circulation in the City of Clawson.

_____)
 Penny Luebs, Mayor

_____)
 G. Machele Kukuk, City Clerk

Dated:_____

Dated:_____